

**THE VILLAGE OF RINGWOOD
ORDINANCE NO. 02-01-2010**

**ADOPTED BY THE PRESIDENT AND BOARD OF TRUSTEES
OF THE VILLAGE OF RINGWOOD THIS 18th DAY OF FEBRUARY, 2010**

Published in pamphlet form by
authority of the President and
Board of Trustees of the Village
of Ringwood, McHenry County,
Illinois this 18th day of February, 2010

ORDINANCE NO. 02-01-2010

**AN ORDINANCE AMENDING SECTION 608.1 OF THE SUBDIVISION
CONTROL ORDINANCE RELATING TO MINIMUM DESIGN STANDARDS
FOR SUBDIVISION ROADS AND SECTION 604.8 RELATING TO
LANDSCAPING**

**BE IT ORDAINED BY THE PRESIDENT AND BOARD OF TRUSTEES
OF THE VILLAGE OF RINGWOOD, ILLINOIS, as follows:**

SECTION 1. Section 608.1 of the Subdivision Control Ordinance relating to minimum design standards for subdivision roads is hereby amended in accordance with the minimum design requirements set forth in Exhibit "A" attached hereto and made a part hereof.

SECTION 2. Section 604.8 of the Subdivision Control Ordinance is hereby amended to provide as follows:

"604.8. Landscaping: Prior to the acceptance of streets in a subdivision, all road frontages shall be planted with native trees of a hardy variety (oak, hickory, hard maple) that can withstand a street-side environment. The trees, at the time of planting, shall have a trunk diameter of no less than three (3) inches. A minimum of one (1) tree per every thirty (30) feet of all sides of the lot line abutting a street shall be required. However, this does not mean that the trees must be planted thirty (30) feet on center. The trees shall be planted within the yard adjacent to the said street right-of-way lines and not within any easement prohibiting plantings."

SECTION 3. Any person, firm, or corporation violating any provision of this ordinance shall be fined not less than Fifty (\$50.00) Dollars nor more than Seven Hundred Fifty (\$750.00) Dollars for each offense committed on each day during or on which a violation occurs or continues.

SECTION 4. All ordinances, or parts thereof, in conflict with the terms and provisions hereof, be and the same hereby are repealed to the extent of such conflict.

SECTION 5. This ordinance shall be published in pamphlet form by and under the authority of the Corporate Authorities of the Village.

SECTION 6. This ordinance shall be in full force and effect from and after its passage, approval and publication in pamphlet form, as provided by law.

PASSED THIS 18th DAY OF FEBRUARY, 2010

AYES: Trustees Mudra, Dercole, Kepes, House and Bushroe

NAYS: None

ABSTAIN: None

ABSENT: Trustee Bauer

NOT VOTING: None

APPROVED THIS 18th DAY OF FEBRUARY, 2010



VILLAGE PRESIDENT

ATTEST:

VILLAGE CLERK

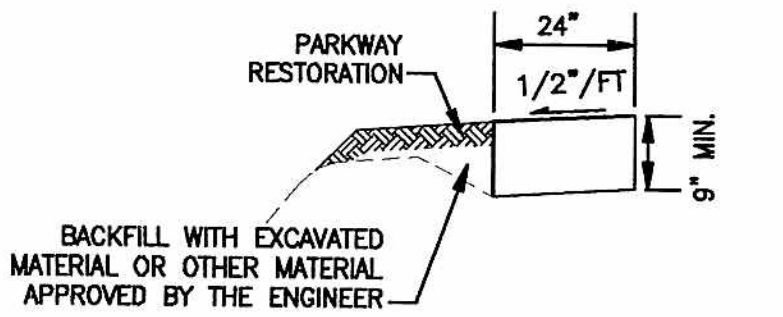

File with ord.



PORTLAND CEMENT CONCRETE SHOULDERS, 24" (SPECIAL)

NO SCALE

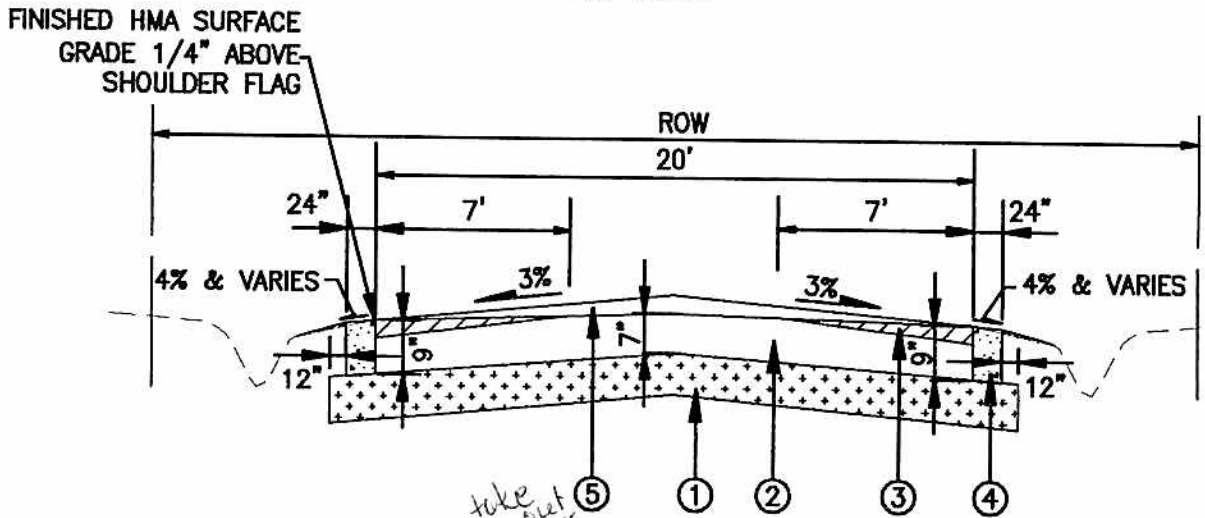

PROPOSED TYPICAL SECTION (NOT TO SCALE)

LEGEND

- ① SUBBASE GRANULAR MATERIAL, TYPE B - 8"
- ② HOT-MIX ASPHALT BASE COURSE 7" (INSTALL 9" AT SHOULDER FLAG)
- ③ HMA SURFACE REMOVAL (VARIABLE DEPTH) 7-FEET WIDE PRIOR TO INSTALLING SURFACE COURSE
- ④ PORTLAND CEMENT CONCRETE SHOULDERS 24" (SPECIAL) (SHOULDER FLAG DEPTH - 9")
- ⑤ HOT-MIX ASPHALT CONCRETE SURFACE COURSE, MIX "C", N50 - 2"

I:\RINGW\General\Details\Concrete Shoulder_Rev.dwg - SH5
 Plotted: 1-27-10 @ 3:06pm By: 560kar
 Copyright © 2009, By Baxter & Woodman, Inc.
 State of Illinois - Professional Design Firm
 License No. - 184-001121 - Expires 4-30-11

BAXTER

WOODMAN
 Consulting Engineers

Baxter & Woodman
 Crystal Lake, Illinois
 Burlington, Wisconsin
 Mokena, Illinois
 DeKalb, Illinois
 Grayslake, Illinois
 Rockford, Illinois

VILLAGE OF RINGWOOD, ILLINOIS
CONCRETE SHOULDER DETAIL
AND ROADWAY TYPICAL SECTION

DESIGNED BY JJF	SCALE NO SCALE
DRAWN BY JJF	PROJECT NO.
CHECKED BY JJF	SHEET NO.
DATE 01-27-10	1 OF 1

Exhibit A